

# VANDAL PROOF DOME CAMERA

## DCC-700DV

**680TVL, ATR  
Sony Effio, NR**

### Features

- SONY 1/3" 480K/570K-Effective Pixel Ex-view HAD CCD II
- High Resolution: More than 680 TV Lines
- NR (Digital Noise Reduction), High Color Reproduction
- ATR (Adaptive Tone Reproduction), Privacy Zone
- High sensitivity and high saturation signal, OSD (8 languages)
- 4~9mm Auto Iris Lens (Option: 2.8~10mm, 2.8~12mm)
- Weather-proof ( IP66 )

### Picture



### Dimensions

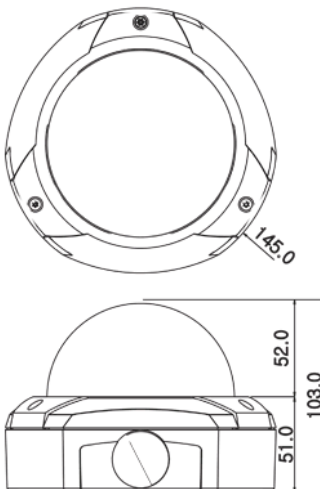

unit : mm

### Specifications

MODEL	DCC-700DV	
Signal system	NTSC	PAL
Image Sensor	1/3" Sony 480K/570K Ex-view super HAD CCD II	
Total Pixels	1020(H)X508(V)	1020(H)X596(V)
Effective Pixels	976(H)X494(V)	976(H)X582(V)
Resolution	680 TV lines (B/W 700 TV Lines)	
Scanning Frequency	15.734KHz(H), 60(V)	15.625KHz(H), 50(V)
Shutter Speed	1/60~1/120,000 sec	1/50~1/100,000 sec
Min. Illumination	Color 0.1Lux(50IRE) @F1.2 / B/W 0.08Lux(50IRE)	
Day & Night	Color / Auto / B/W	
ATR	On / Off	
White Balance	ATW / PUSH / USER1 / USER2 / ANTI CR / MANUAL / PUSH LOCK	
Back Light	BLC / HLC	
AGC	Level setting	
NR	On / Off	
Privacy Zone	8 Programmable Zone	
Motion Detection	4 Programmable Zone	
Sharpness	Level setting	
Camera ID	On / Off	
S/N Ratio	More than 52dB	
Video Output	Composite video output 75 ohm terminated	
Lens	4~9mm DC Auto Iris Lens	
Sync. System	Internal	
Operating Humidity	30 % ~ 90 % RH	
Operating Temp.	- 10°C to 50°	
Dimension	φ120(Bubble) x 103(H)mm	
Weight	About 1.1kg	
Power Consumption	Max 2.5W	
Power Supply	DC 12 V(10.2V~14.5 V) Dual Voltage(Option) : AC24V / DC12V	