

VANDAL PROOF DOME CAMERA

DCC-608DV



560TVL, WDR
Day & Night, 3D DNR

FEATURES

- 410K Pixel double density interline Sony 1/3" CCD
- Powerful 128X WDR function(Max.52dB)
- Digital Day & Night
- DNR (Digital Noise Reduction) for Reducing HDD capacity
- Easy Adjustment with 3 Axis
- 3.6mm Fixed Lens
- High-Impact Vandal Proof Dome Housing

DIMENSIONS

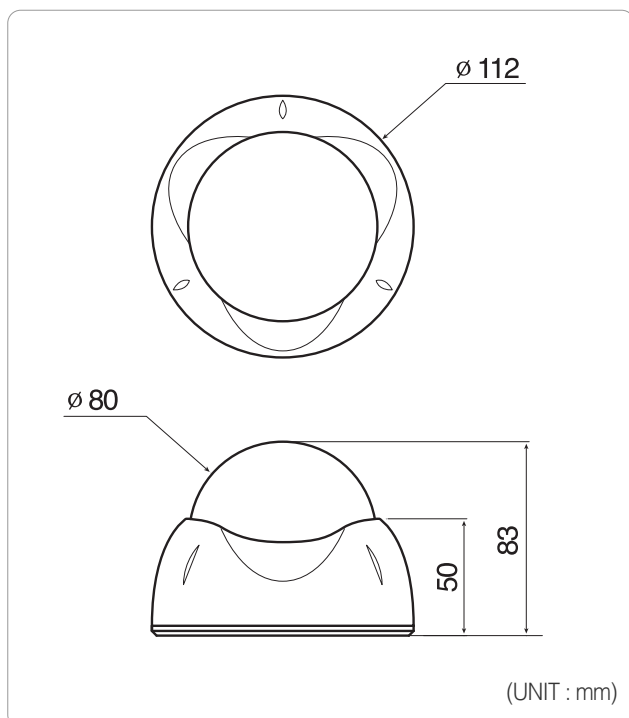

SPECIFICATIONS

MODEL	DCC-608DV	
Signal system	NTSC	PAL
Image sensor	1/3" double density interline Sony CCD	
Total pixels	811(H) × 508(V)	795(H) × 596(V)
Effective pixels	768(H) × 494(V)	752(H) × 582(V)
Resolution	More than 560 TV lines	
Scanning frequency	15,734KHz(H), 60(V)	15,625KHz(H), 50(V)
Shutter speed	1/60~1/100,000 sec	1/50~1/100,000 sec
Minimum illumination	Color : 0.3 Lux@F1.2(Color) 0.00004Lux (Sense-up)	
Day & Night	D&N Function by Digital Change : Auto/Off	
Shutter	Auto	
White balance	Auto	
BLC	Auto	
AGC	Auto	
DNR	Auto	
Sharpness	Auto	
S/N ratio	More than 52dB	
Video output	Composite video output 75Ω terminated	
Lens	3.6mm Fixed Lens DC Auto Iris Lens 4~9mm (Option)	
Sync. system	Internal	
Operating humidity	30% ~ 90% RH	
Operating temperature	-10°C to 50°	
Dimension	∅80(Bubble) × 83(H)	
Weight	About 600g	
Power consumption	Max 1.8W	
Power supply	DC 12V(±10%)	