

VANDAL PROOF DOME CAMERA

DCC-601DV

**560TVL, WDR
Day & Night, DNR**

Features

- Max 560 Horizontal TV Lines
- WDR (Wide Dynamic Range), 3D-DNR (Noise Reduction)
- Sense-Up (x128) / Low Luminance Light
- EIS (Electronic Image Stabilizer), Motion Detection (4 Zones), Privacy Masking (8 Area)
- HSBLC (Highlight Suppress BLC), Digital Zoom X8, Multi Language support
- 4~9mm Auto Iris Lens (Option : 2.8~10mm, 2.8~12mm)

Picture



Dimensions

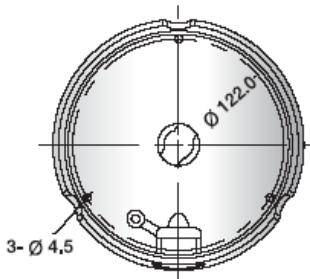
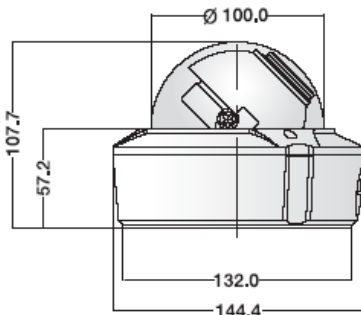

unit : mm

Specifications

MODEL	DCC-601DV	
Signal system	NTSC	PAL
Image Sensor	1/3" double density interline Sony CCD	
Total Pixels	811(H)X508(V)	795(H)X596(V)
Effective Pixels	768(H)X494(V)	752(H)X582(V)
Resolution	560 TV lines (B/W : 700 TV lines with ICR)	
Scanning Frequency	15.734KHz(H), 60(V)	15.625KHz(H), 50(V)
Shutter Speed	1/60~1/100,000 sec	1/50~1/100,000 sec
Min. Illumination	0.00004Lux (Sense-up 128x)	
Day & Night	Day / Night / Auto / EXT True Day & Night with ICR (Option)	
EIS	On / Off	
Digital Zoom	X8	
Digital Effect	Off / V-Flip / Mirror / Rotate	
White Balance	ATW / AWC / Manual	
BackLight	BLC / WDR(60dB) / HSBLC	
Wide Dynamic Range	52 dB	
AGC	Low / Middle / High / Off	
3D-DNR	Off / Low / Middle / High	
Privacy Zone / Motion Detection	8 Area / 4 Zone	
Sharpness	Adjustable	
Camera ID	On(1~255) / Off	
S/N Ratio	More than 52dB	
Video Output	Composite video output 75 ohm terminated	
Lens	4~9mm Auto Iris Lens	
Sync. System	Internal	
Operating Humidity	30 % ~ 90 % RH	
Operating Temp.	- 10°C to 50°	
Dimension	φ100(Bubble) x 107.7(H)mm	
Weight	About 1.1kg	
Power Consumption	Max 2.5W	
Power Supply	DC 12 V(10.2V~14.5 V) Dual Voltage(Option) : AC24V / DC12V	