

VANDAL PROOF DOME CAMERA

DCC-528DV

620TVL, DNR
3 Axis

Features

- 410K Pixel, 1/3" Sony Color CCD
- High Resolution up to 620 TVL
- Digital Day & Night
- Easy adjustment with 3 Axis
- 4~9mm DC Auto Iris Lens
- Weather-proof, High-Impact Vandal Proof Dome Housing

Picture



Dimensions

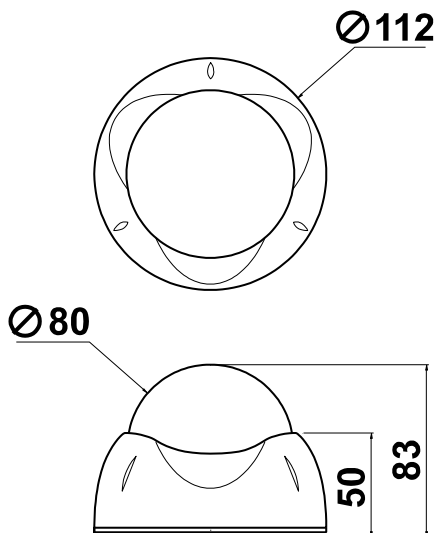

unit : mm

Specifications

MODEL	DCC-528DV	
Signal system	NTSC	PAL
Image sensor	1/3" Sony Super HAD CCD	
Total pixels	811(H)X508(V)	795(H)X596(V)
Effective pixels	768(H)X494(V)	752(H)X582(V)
Resolution	More than 620 TVL	
Scanning frequency	15.734KHz(H), 60(V)	15.625KHz(H), 50(V)
Shutter speed	1/60~1/100,000 sec	1/50~1/100,000 sec
Minimum illumination	0.1 Lux@F1.2	
Digital Day & Night	Auto	
White balance	ATW	
AGC	Auto	
IP rate	65	
S/N ratio	More than 50dB	
Video output	Composite video output 75Ω terminated	
Lens	4-9mm Auto Iris lens	
Sync. system	Internal	
Operating humidity	30 % ~ 90 % RH	
Operating temperature	- 10°C to 50°	
Materials	Aluminum Body (Ivory) PC Bubble	
Dimension	φ80(Bubble) x 83(H)	
Weight	About 600g	
Power consumption	Max 1.8W	
Power supply	DC 12 V(10.2V~14.5 V)	