

VANDAL PROOF DOME CAMERA

DCC-508DV

600TVL, 3DNR
3 Axis

Features

- 410K Pixel Sony 1/3" CCD
- High Resolution of 600 TV Lines
- Low up to 0.02Lux., Day & Night
- 3D-DNR (Digital Noise Reduction)
- Built-in 3.6mm Fixed Lens (Option : 4~9mm, 2.8~12mm)
- Weather-proof, High-Impact Vandal Proof Dome Housing

Picture



Dimensions

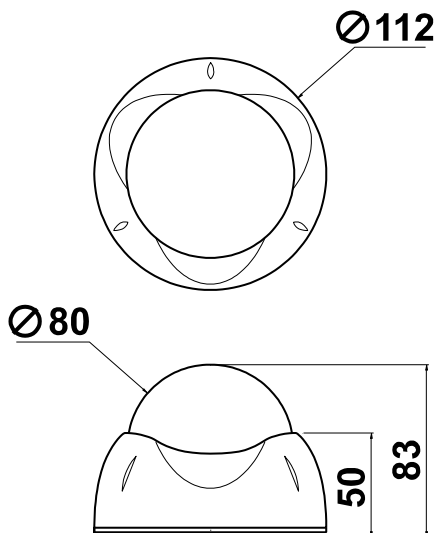

unit : mm

Specifications

MODEL	DCC-508DV	
Signal system	NTSC	PAL
Image sensor	1/3" Sony Super HAD CCD	
Total pixels	811(H)X508(V)	795(H)X596(V)
Effective pixels	768(H)X494(V)	752(H)X582(V)
Resolution	600 TV lines	
Scanning frequency	15.734KHz(H), 60(V)	15.625KHz(H), 50(V)
Shutter speed	1/60~1/100,000 sec	1/50~1/100,000 sec
Minimum illumination	Color : 0.02 Lux., Sense-up : Auto(4x)	
Day & Night	Auto/Off(Default)	
Shutter	Auto	
White balance	Auto	
BLC	Auto	
AGC	Auto	
DNR	Auto	
Sharpness	Auto	
S/N ratio	More than 50dB	
Video output	Composite video output 75Ω terminated	
Lens	3.6mm Fixed Lens	
Sync. system	Internal	
Operating humidity	30 % ~ 90 % RH	
Operating temperature	- 10°C to 50°	
Dimension	φ80(Bubble) x 83(H)	
Weight	About 600g	
Power consumption	Max 1.8W	
Power supply	DC 12 V(10.2V~14.5 V)	