

VANDAL PROOF DOME CAMERA

DCC-501DV

**600TVL, DSS
Day & Night, 3DNR**

Features

- High Resolution of 600 TV Lines
- Low up to 0.00001 Lux., Day & Night
- Digital WDR, Privacy Masking Zone, Motion Detection Function
- 3D-DNR (Digital Noise Reduction), Digital Zoom(32x), White Defect Restoration
- Built-in OSD (On Screen Display) Menu, Multi Language support
- Built-in 4~9mm Auto Iris Lens
- Option Lens (2.8~10mm, 2.8~12mm)
- Weather-proof (IP66)

Picture



Dimensions

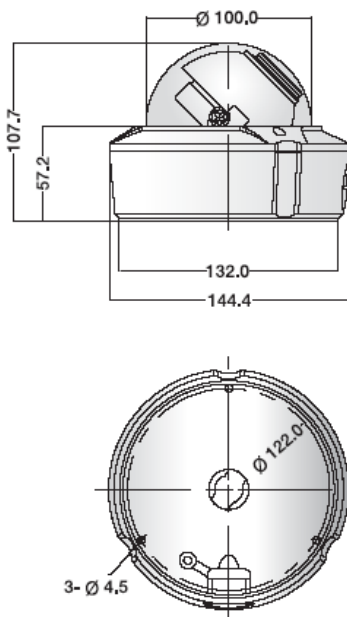

unit : mm

Specifications

MODEL	DCC-501DV	
Signal system	NTSC	PAL
Image Sensor	1/3" Sony Super HAD CCD	
Total Pixels	811(H)X508(V)	795(H)X596(V)
Effective Pixels	768(H)X494(V)	752(H)X582(V)
Resolution	Color : 600 TV lines (B/W : 700 TV Lines with ICR)	
Scanning Frequency	15.734KHz(H), 60(V)	15.625KHz(H), 50(V)
Shutter Speed	1/60~1/100,000 sec/ FLK	1/50~1/100,000 sec/ FLK
Min. Illumination	Color : 0.1 Lux@F1.2 0.00001Lux (Sense-up 256x)	
Day & Night	Color / Auto / EXT / B/W True Day & Night with ICR (Option)	
Digital WDR	On / Off	
White Balance	ATW / AWB / AWC-Set / Manual / Indoor / Outdoor	
BLC	BLC / HSBLC	
AGC	Low / Middle / High / Off	
3D-DNR	On / Off	
Privacy Zone	8 Programmable Zones	
Motion Detection	4 Programmable Zones	
Sharpness	Level : 0 ~ 31	
Camera Title	On / Off	
S/N Ratio	More than 52dB	
Video Output	Composite video output 75 ohm terminated	
Lens	4~9mm DC Auto Iris Lens	
Sync. System	Internal	
Operating Humidity	30 % ~ 90 % RH	
Operating Temp.	- 10°C to 50°	
Dimension	φ100(Bubble) x 107.5(H)	
Weight	About 1.1 kg	
Power Consumption	Max 2.5W	
Power Supply	DC 12 V(10.2V~14.5 V) Dual Voltage(Optional) : AC24V / DC12V	