

PEED DOME CAMERA

DSC-3000Si

**592X ZOOM, 600TVL
TDN, 0.00004Lux**

Features

- 410K Pixel, 1/4" SONY Super HAD CCD
- Horizontal Resolution: 600 TVL(Color), 700TVL(B/W)
- 37x Auto Focus Optical Zoom, 16x Digital Zoom with Infrared Cut filter removal Day & Night
- Digital Slow Shutter (Min. illumination 0.00004Lux), Digital image stabilizer(DIS)
- Auto Flip (Automatically 180° Turning), Protection for Low Voltage,
- A variety of surveillance with Swing(2), Presets(250), Group(8), Tour, Trace, Spiral, Alarm (8In/2Out)

Specifications



Dimensions

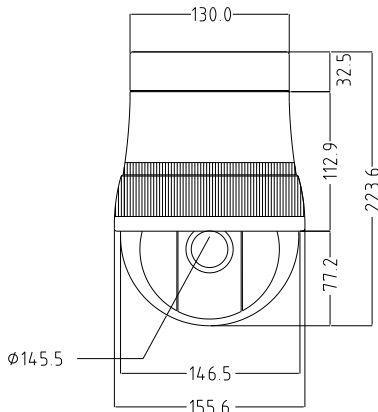

unit : mm

MODEL	DSC-3000Si	
Signal system	NTSC	PAL
Image sensor	1/4" Sony Super HAD CCD	
Effective pixels	768(H) X 494(V),	752(H) X 582(V),
Horizontal resolution	Color : 600 TVL, B/W : 700 TVL	
Lens	37x Optical zoom, f =3.5 –129.5mm	
Digital zoom	16x (Total zoom 592x)	
Angle of view	H : 55.5° ~1.59° , V : 42.5° ~1.19°	
Minimum illumination	0.5 Lux , 0.1Lux(D&N), Min 0.00004Lux(DSS),/F1.6	
Luminance S/N ratio	More than 52Db	
Video output	1 Vp-p Composite video output 75Ω	
Focus mode	Auto / Manual / Oneshot	
DNR	Off / Low / Middle / Max	
Back Light	BLC / HLC / WDR	
Shutter speed	Auto / 1/120 ~ 1/60,000 sec	
Sharpness control	Level (0 – 10)	
Stabilizer	On/Off	
Alarm in/out	8 Inputs / 2 Relay Output	
Pan/Tilt angle	360° Endless / 92°	
Pan speed	0.1° ~ 240°/sec (64 Levels)	
Preset point	250 Presets	
Preset Speed	Max 360°/sec (64 Levels)	
Privacy zones masking	16 Zones	
Operating temperature	- 10°C ~ 50°C (14°F ~ 122°F)	
Communication system	RS-485	
Operating humidity	Less than 90%RH	
Dimensions	155.6mm(Diameter) x 223.6mm(Height)	
Weight	About 3.1Kg (Without adaptor)	
Construction	ABS body , Clear vandal bubble (PC)	
Power consumption	18W (Max)	
Power supply	AC24V, 60/50 Hz	