

# COLOR BOX CAMERA

## DCC-520F(DN)

### Features

- 410K Pixel Sony 1/3" CCD
- High Resolution of 620TV Lines
- Privacy Masking (4 Zones), Motion Detection
- Built-in OSD (On Screen Display) Menu
- Day & Night, BLC, AGC, Auto White Balance, White Defect Restoration
- C/CS Mount Lens

**620TVL, DNR  
True Day & Night**

### Picture



### Dimensions

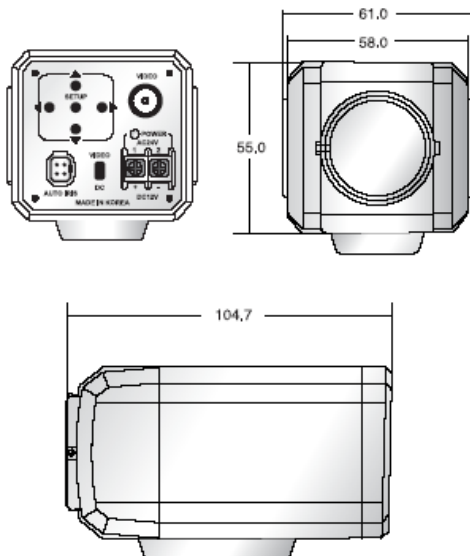

unit : mm

### Specifications

MODEL	DCC-520F(DN)	
Signal system	NTSC	PAL
Image sensor	1/3" Sony super HAD CCD	
Total pixels	811(H)X508(V)	795(H)X596(V)
Effective pixels	768(H)X494(V)	752(H)X582(V)
Resolution	Color : 620 TV Lines (B/W 700 TV Lines with ICR)	
Scanning frequency	15.734KHz(H), 60(V)	15.625KHz(H), 50(V)
Shutter speed	1/60~1/100,000 sec	1/50~1/100,000 sec
Minimum illumination	0.1 Lux @F1.2	
Mirror	On / Off	
Shutter	Fixed / Manual / Flickerless	
White Balance	ATW / Manual / AWB / Fixed	
DNR	On / Off	
BLC	On / Off	
Day & Night	On / Off / Auto	
Privacy zones masking	4 Zones	
AGC	On / Off	
Camera ID	On / Off	
Language	English / Japanese / Chinese	
S/N ratio	More than 50dB	
Video output	Composite video output 75Ω terminated	
Lens mount	C / CS Mount	
Sync. system	Internal	
Operating humidity	30 % ~ 90 % RH	
Operating temperature	- 10°C to 50°	
Dimension	63.7(W) X 55.5(H) X 105.5(D)mm	
Weight	About 420g	
Power consumption	Max 3W	
Power supply	DC 12 V(10.2V~14.5 V) Dual Voltage(Optional) : AC24V / DC12V	